

# MACT403 series

AIR UNIT (F.R.L.UNIT)



Mindman



Option: MP41

## Symbol

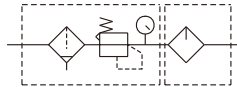

## Specification

Model	MACT403		
Components	MAF403, MAR403, MAL403		
Bore No.	8A	10A	15A
Port size	1/4	3/8	1/2
Medium	Air		
Operating pressure range	0.05~1 MPa		
Proof pressure	1.5 MPa		
Regulated pressure range	0.1~0.85 MPa		
Ambient temperature	-5~+60°C (no freezing)		
Filter element	Standard: 40 μm Option: 5 μm		
Lubricating oil capacity	140 c.c		
Min. Flow for oil drip	30 ℓ/min	65 ℓ/min	80 ℓ/min
Recommended lubricating oil	Turbine oil ISO-VG32		
Attachment	Pressure gauge (PG-20), L-type bracket		
Weight	1345 g		

※1. Standard unit contains semi-auto-drain function when operating pressure below 0.05 MPa.

※2. Choose auto-drain FMRF300, the pressure range is 0.15 ~ 1 MPa.

## Order example

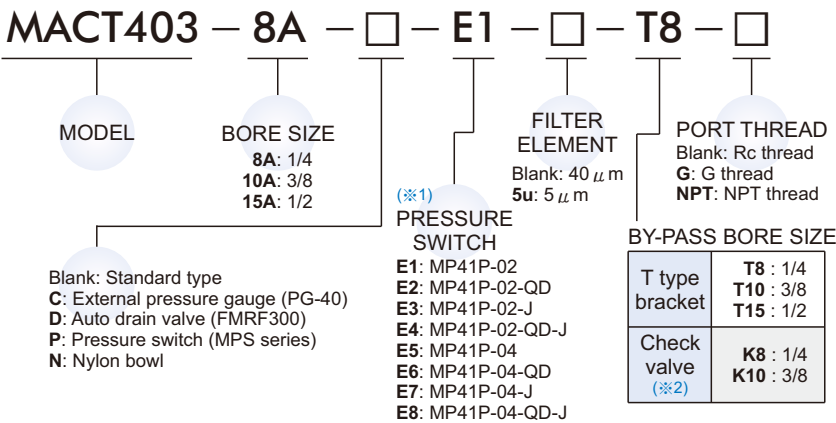

## Flow feature

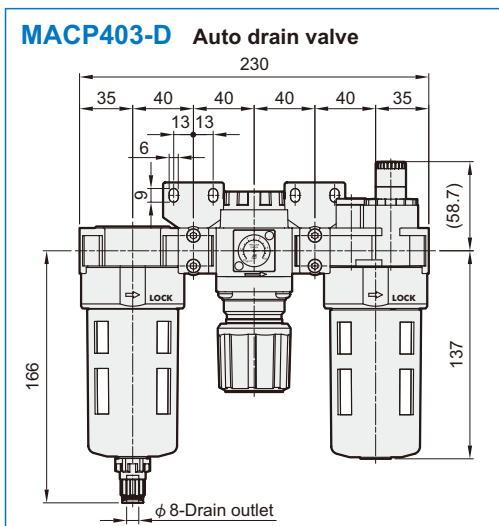
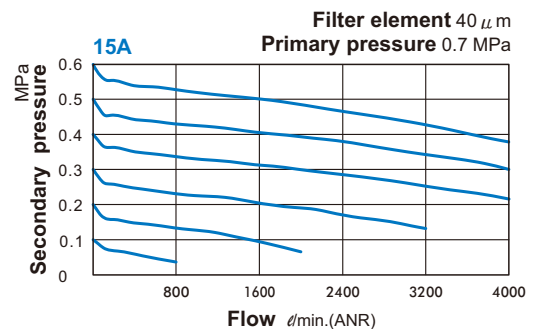
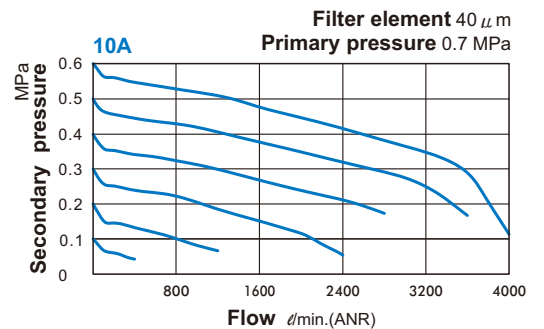
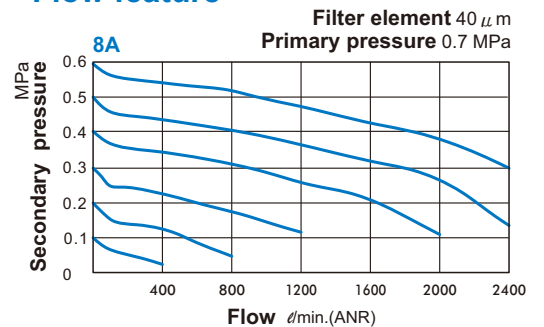

# MACT403 Dimensions

AIR UNIT (F.R.L.UNIT)



## MACT403-T\*

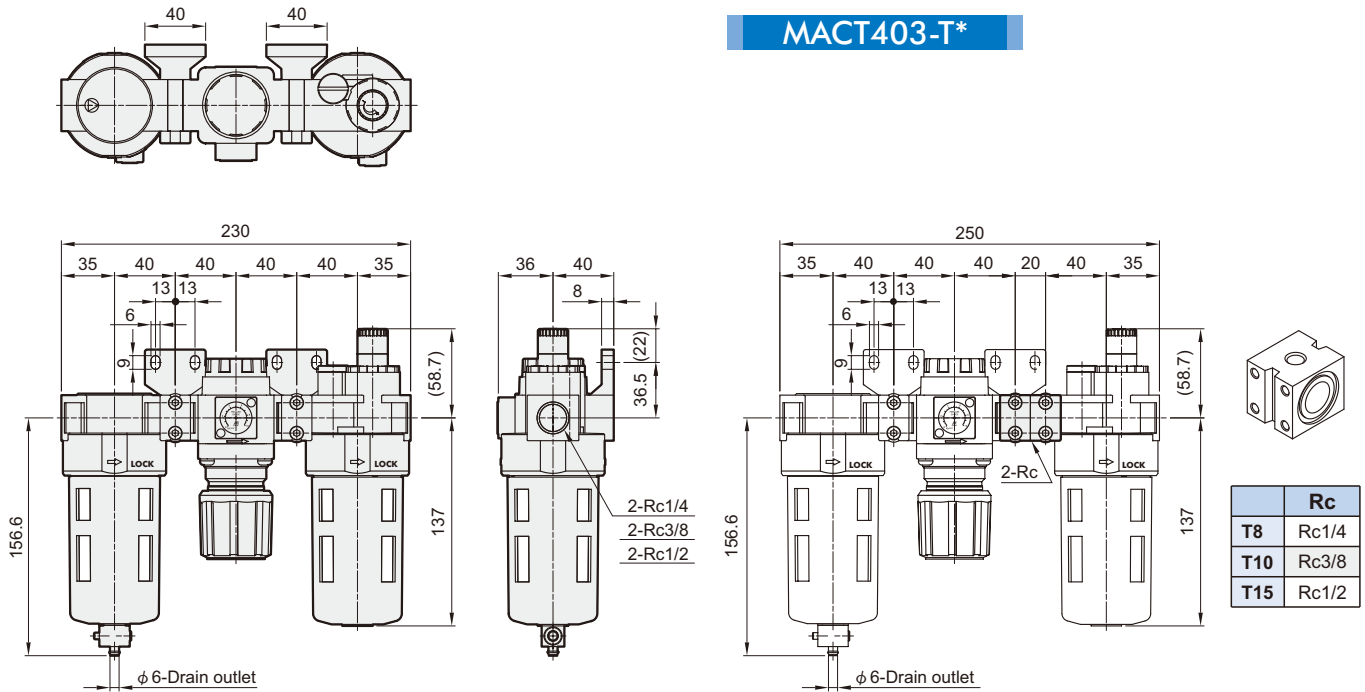

## MACT403-K\*

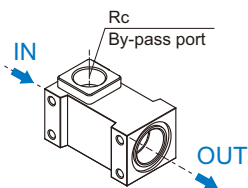
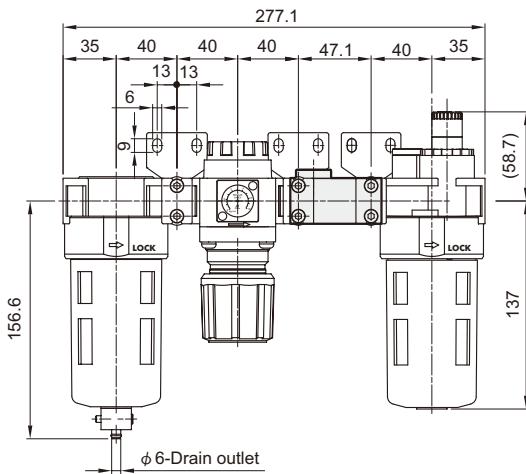

	Rc
K8	Rc1/4
K10	Rc3/8

※ Threads for IN and OUT ports aren't machined.

## MACT403-P

MPS Series  
pneumatic pressure switch

