

MAR400 series

AIR UNIT (R.UNIT)

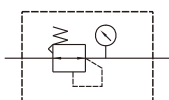

Symbol



Specification

Model	MAR400		
Bore No.	8A	10A	15A
Port size	1/4	3/8	1/2
Medium	Air		
Max. operating pressure	1 MPa		
Proof pressure	1.5 MPa		
Regulated pressure range	0.05~0.85 MPa		
Ambient temperature	-5~+60°C (No freezing)		
Attachment	Pressure gauge (PG-50), bracket		
Weight	1000 g		

Order example

MAR400 — 8A — □

MODEL

BORE SIZE

8A: 1/4
10A: 3/8
15A: 1/2

PORT THREAD

Blank: Rc thread
G: G thread
NPT: NPT thread

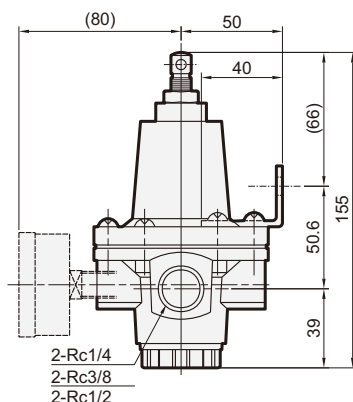
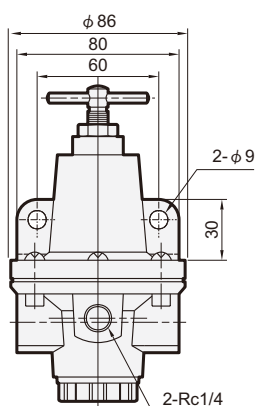

Flow feature

