



Features

- Cylinder thrust should be 70% (50% of Maximum Speed) of theoretical force.
- Displacement should be approximately 50% of total volume.
- Maximum acceleration is approximately 200mm/sec.
- ISO-VG32 or an equivalent oil is recommended.
- Oil feed should not exceed 80% of total volume.
- Unit should be installed vertically above the cylinder / actuator.

Model	MCQA-AH
Tube I.D. (mm)	40,50,63,80,100,125,150
Medium	ISO VG32 EQUIVALENT
Operating pressure range	0.05~1 MPa
Proof pressure	1.5 MPa
Ambient temperature	-5~+60°C (No freezing)
Available speed range	50~500 mm/sec

Order example

MCQA-50×100-AH

MODEL

LENGTH

TUBE I.D.

TYPE



Mounting accessories

LB-MCQA-40

MODEL

TUBE I.D.

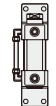
MOUNTING TYPE

	LB
	FBC

MCQA-AH Dimensions $\phi 40 \sim \phi 100$

AIR/OIL CONVERTER — INSTALLED UPRIGHTLY



Mindman

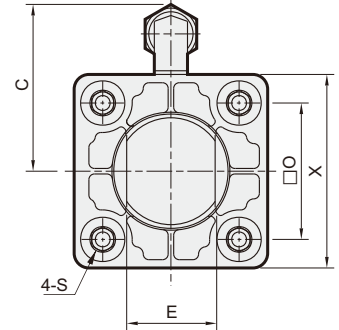
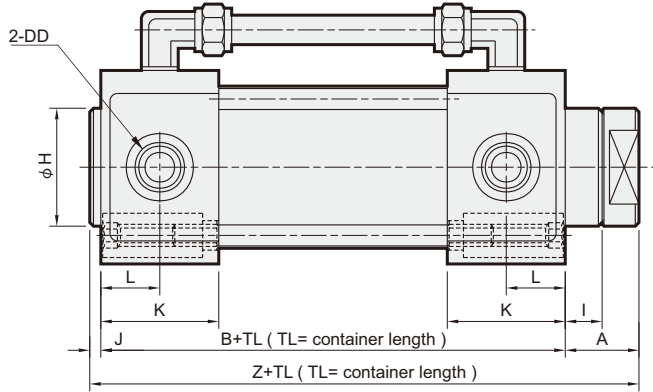

LB

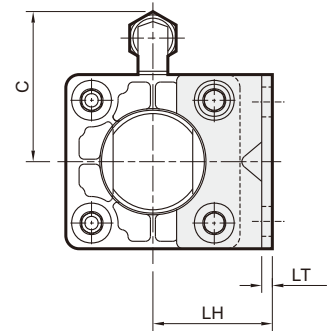
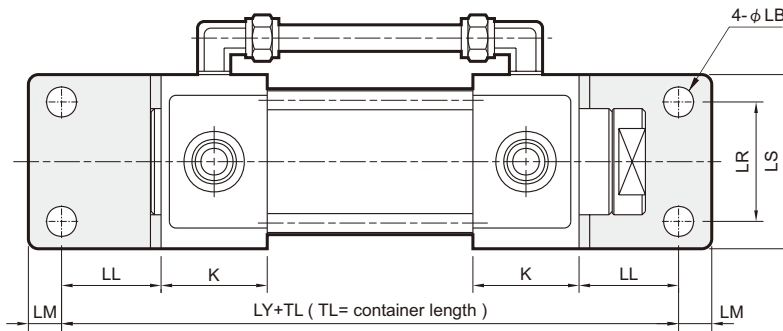

FBC

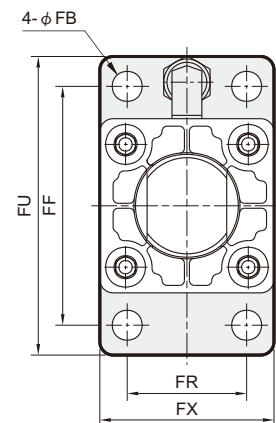
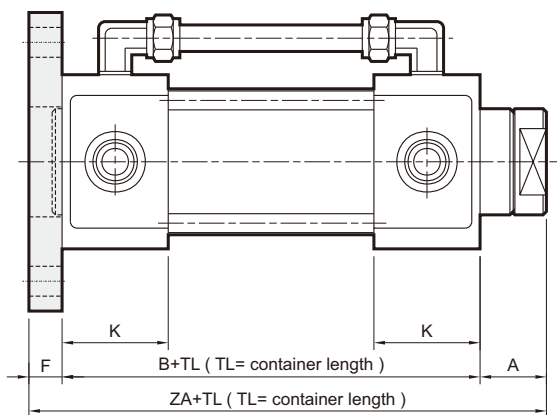

Code Tube I.D.	A	B	C	DD	E	F	FB	FF	FR	FU	FX	H	I	J	K	L	LB	LH	LL	LM	LR	LS	LT	LY	O	S	X	Z	ZA
40	21	62	49	Rc1/4	24	12	9	80	42	100	65	32	11	3	26	13	9	40	27	13	42	58	3.2	116	40.5	M8×1.25	58	86	95
50	21	66	53	Rc3/8	28	12	9	90	50	110	73	40	11	3	28	14	9	45	27	13	50	66	3.2	120	48	M8×1.25	66	90	99
63	21	72	66	Rc3/8	28	15	11.5	105	59	130	84	40	11	3	30	15	11.5	50	34	16	59	80	4.5	140	59	M8×1.25	80	96	108
80	27	82	70	Rc1/2	36	18	14	130	76	160	108	45	15	4	34	17	14	65	44	16	76	100	6.0	170	74	M12×1.75	100	113	127
100	27	90	79	Rc1/2	40	18	14	150	92	180	124	52	15	5	37	18.5	14	75	43	17	92	118	6.0	176	90	M12×1.75	118	122	135

MCQA-AH Dimensions $\phi 125\sim\phi 150$

AIR/OIL CONVERTER — INSTALLED UPRIGHTLY



Mindman

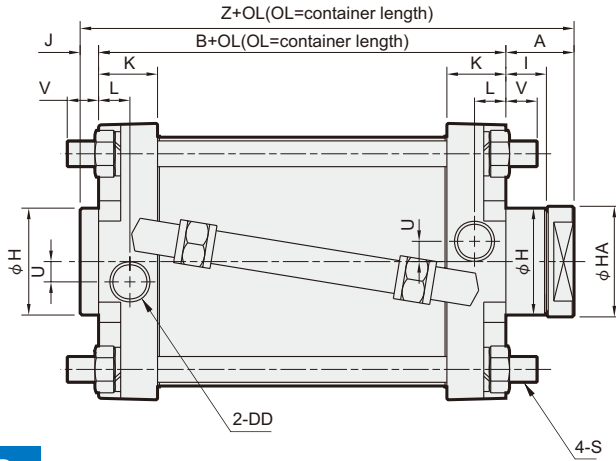

LB

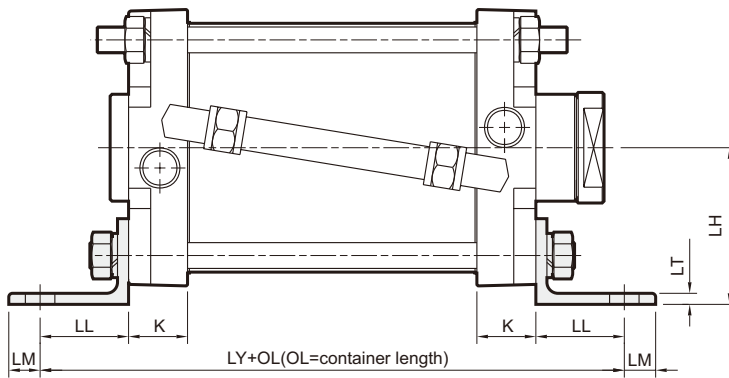
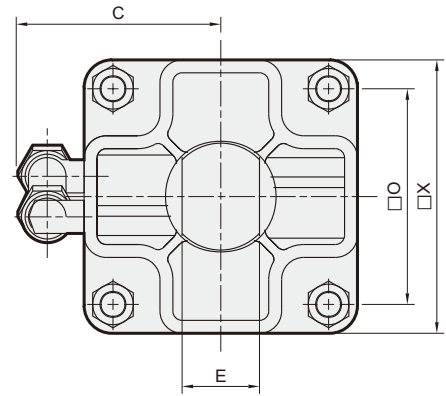

FBC

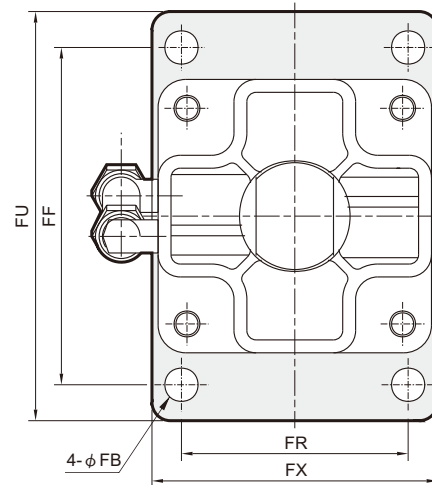
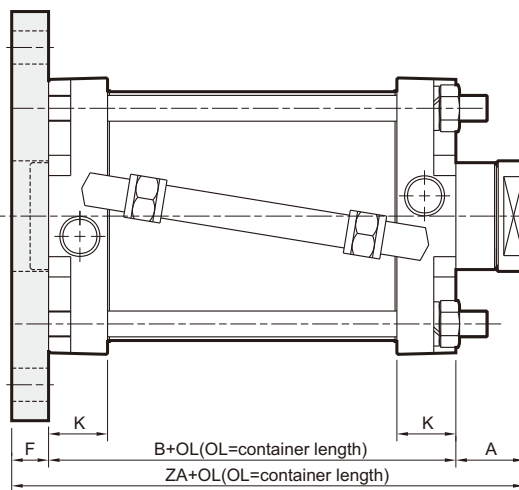
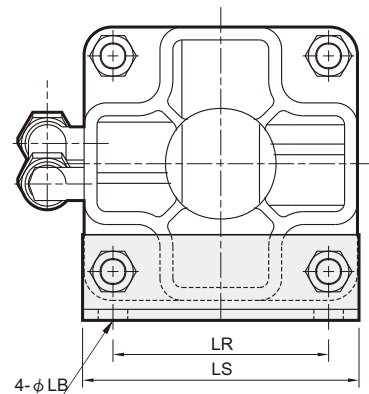

Code Tube I.D.	A	B	C	DD	E	F	FB	FF	FR	FU	FX	H	HA	I	J	K	L	LB	LH	LL	LM	LR	LS	LT	LY	O	S	U	V	X	Z	ZA
125	47	90	95	Rc1/2	42	20	18	183	123	222	155	58	60	32	10	32	17	16	85	48	17	115	151	6	186	117	M14×1.5	11	20	150	147	157
150	47	107	108	Rc1/2	42	20	18	230	134	275	185	60	60	32	8	40.5	24.5	18	96.5	55	20	134	175	9	217	134	M16×1.5	12	26	175	162	174