

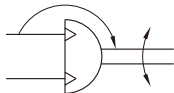

Symbol



Features

- Compact body.
- Functional design with clean appearance.
- Simple mounting of sensors.
- Magnetic as standard.

Specification

Model	MCRA		
Acting type	Double acting		
Tube I.D. (mm)	φ 63		
Port size	Rc1/8		
Medium	Air		
Operating pressure range	0.1~1 MPa		
Proof pressure	1.5 MPa		
Ambient temperature	-5~+60°C (No freezing)		
Acting angle tolerance	0~+4°		
Lubrication	Not required		
Cushion	Air cushion		
Allowable kinetic energy	1.5J (Air cushion)		
Sensor switch (※)	RCB, RCE, RCE1, RDEP		
Weight (kg)	90°	180°	LB
	2.7	3.1	0.4

※ RCB, RCE, RCE1, RDEP specification, please refer to page 5-4, 6, 9.

Order example

MCRA — 63 — 90 — LB — □

MODEL TUBE I.D. PORT THREAD

Blank: Rc thread
G: G thread
NPT: NPT thread

ROTARY ANGLE MOUNTING TYPE

Code	Rotary angle	MOUNTING TYPE
90	90°	Blank
180	180°	LB

Shaft loading

Unit: kgf

Load direction		
Fsa	Fsb	Fr
60	20	30

Torque diagram

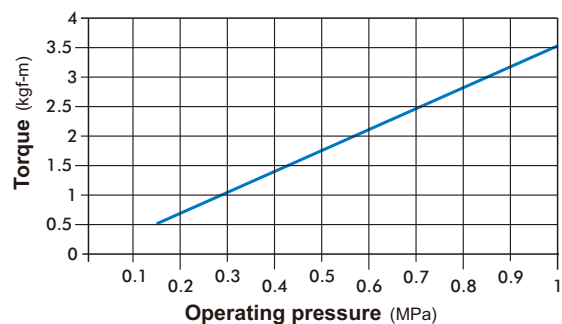

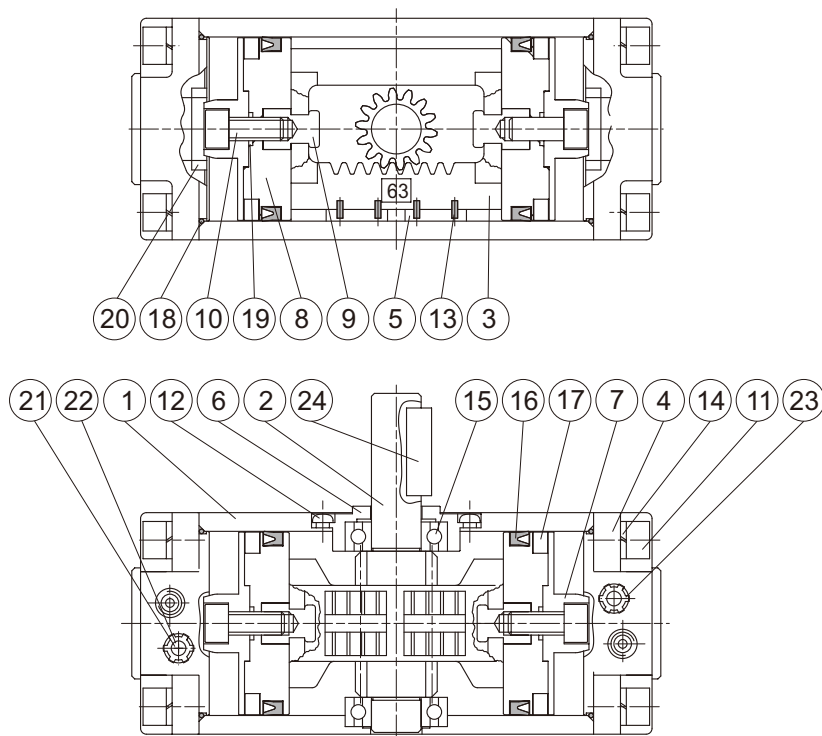

Material

No.	Part name	Material	Q'y	Repair kits (inclusion)
1	Body	Aluminum alloy	1	
2	Shaft	Carbon steel	1	
3	Rack	Carbon steel	1	
4	Cover	Aluminum alloy	2	
5	Slider	Plastic	2	
6	Bearing retainer	Aluminum alloy	1	
7	Piston #1	Aluminum alloy	2	
8	Piston #2	Aluminum alloy	2	
9	Screw #1	Carbon steel	2	
10	Screw #2	SCM	2	
11	Bolt	SCM	8	
12	Screw	SCM	4	
13	Spring pin	Spring steel	4	
14	Spring washer	SCM	8	
15	Bearing	Bearing steel	2	
16	Piston packing	NBR	2	●

No.	Part name	Material	Q'y	Repair kits (inclusion)
17	Magnet ring	Magnet material	2	
18	Gasket	NBR	2	●
19	O-ring	NBR	2	●
20	Cushion packing	NBR	2	
21	Needle valve	Copper	2	
22	Needle valve gasket	NBR	2	●
23	Needle valve washer	Aluminum alloy	2	
24	Parallel key	Carbor steel	1	

Order example of repair kits

Tube I.D.	Repair kits
φ 63	PS-MCRA-63

ROTARY ACTUATOR

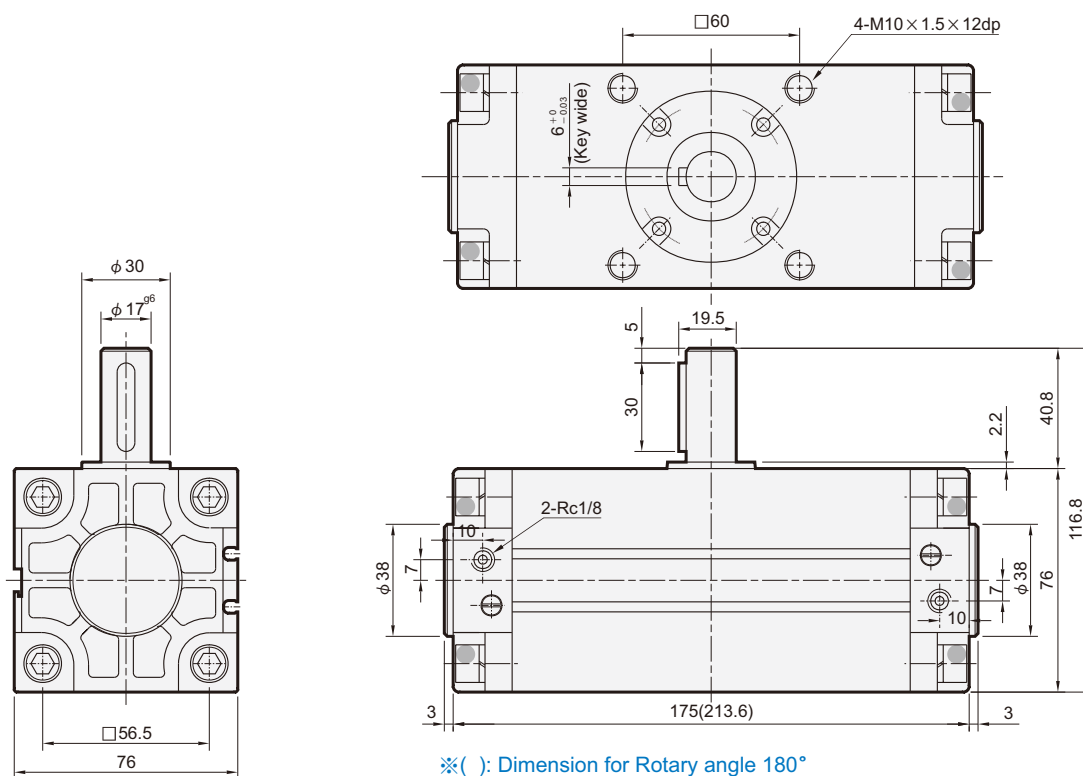

LB

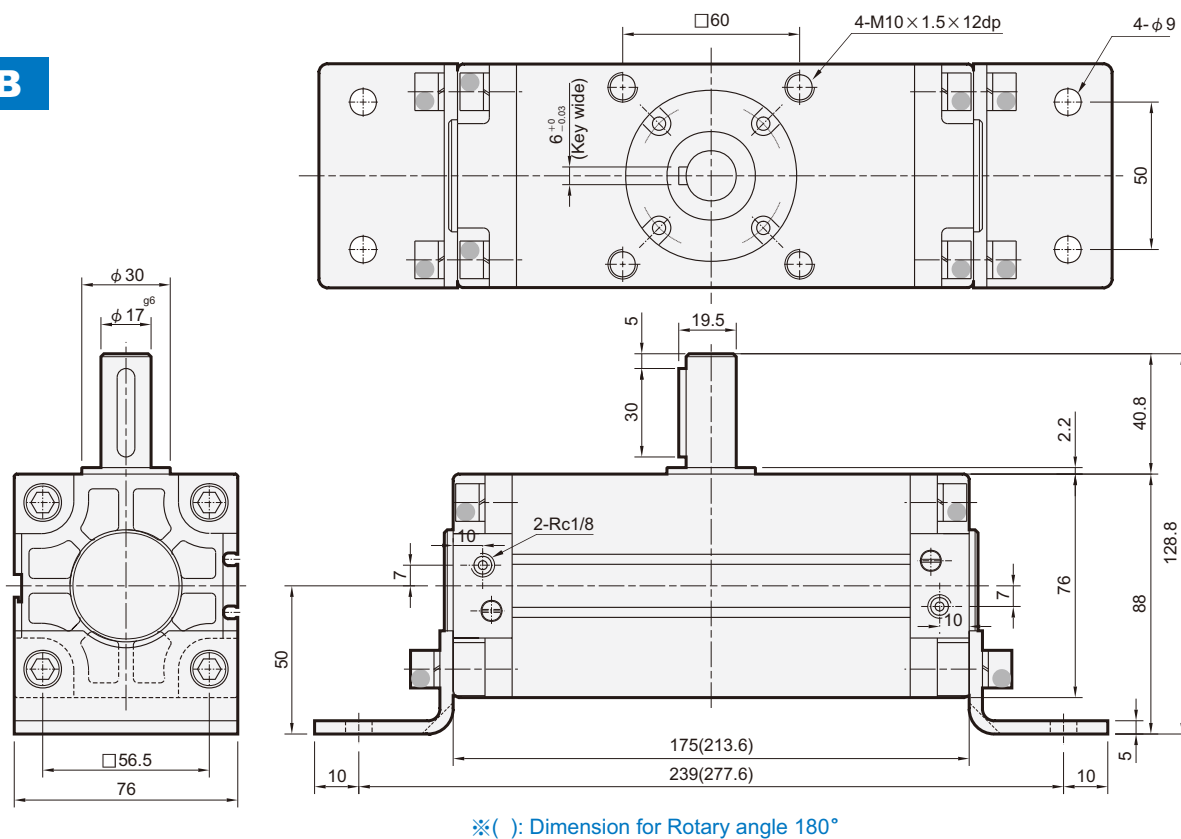

Installation of sensor switch

