

### Table for standard stroke

Tube I.D.	Stroke (mm)	Max. stroke
φ 20	100, 150, 200, 250, 300, 350, 400	1000
φ 25	450, 500, 600, 700, 800	

※ Minimum stroke unit 1mm.

### Order example

**MCRPMS – 20 – 100M – B S – G**

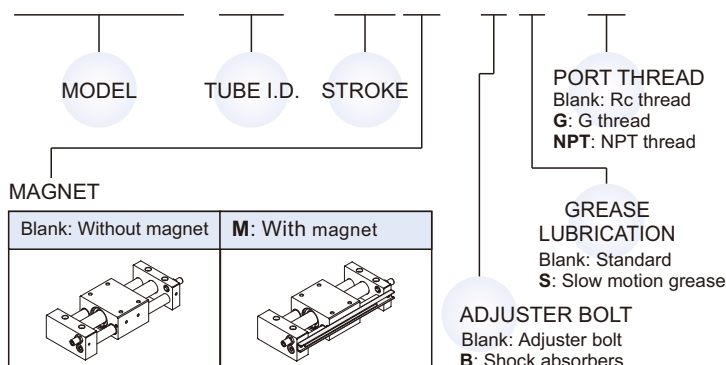

### Cylinder weight

Unit: g

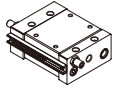
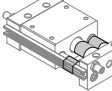
Model	Basic weight MCRPMS	Stroke 100 mm MCRPMS
Tube I.D.		
φ 20	1,433	342
φ 25	1,832	346

### Installation of sensor switch

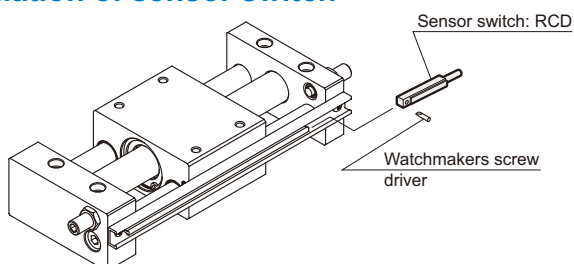

### Features

- 50 % space saving.
- Magnetic transit design. Magnetic force transmits the movement with piston side magnet and slider magnet.
- Stainless tube, light weighted and durable.
- The overall design of the cylinder and guide rods, can direct bear loads.
- Centralized piping ease of mounting.

### Specification

Model	MCRPMS	
Acting type	Double acting	
Tube I.D. (mm)	20	25
Port size	Rc1/8	
Medium	Air	
Max. operating pressure	0.7 MPa	
Min. operating pressure	0.2 MPa	
Proof pressure	1 MPa	
Ambient temperature	+5°C ~ +60°C	
Lubricator	Without lubrication	
Available speed range	Standard grease: 150~400 mm/sec	
	Slow motion grease: 80~150 mm/sec(※1)	
Holding force	231 N	363 N
Shock absorbers	MAC-1007-SN	MAC-1412-SN
Sensor switch (※2)	RCD	

※1. Between the speed range limit the actuator stroke must not exceed to 2m/minute.

※2. RCD specifications, please refer to page 8-9.

### Maximum load mass

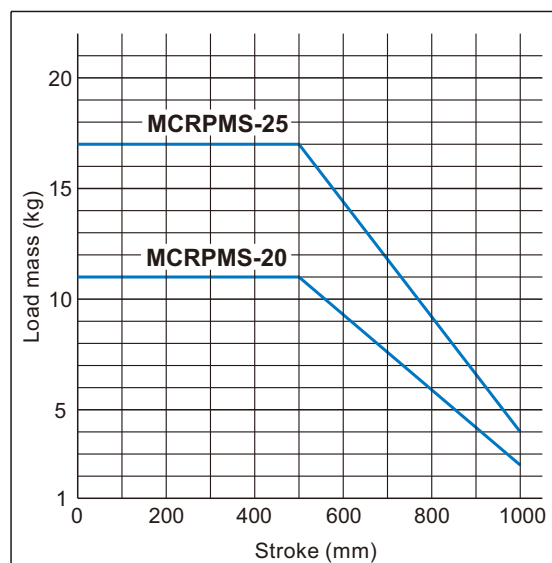

※ Maximum load mass when horizontal mounting.

Section view of A-A

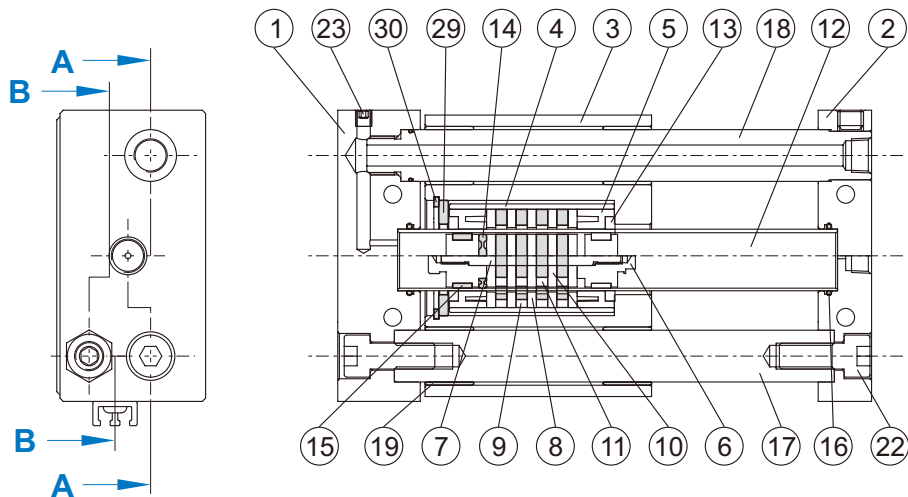

Section view of B-B

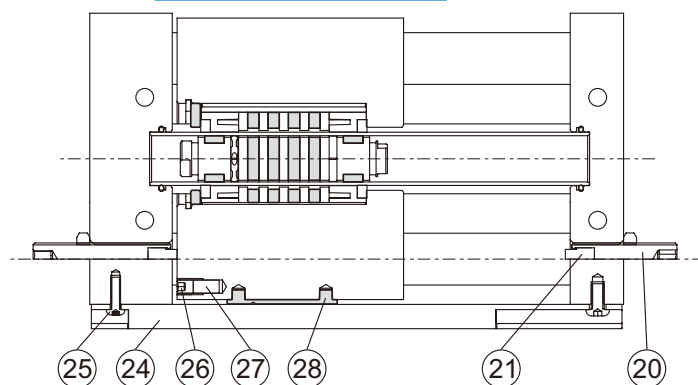

### Material

No.	Part name	Material	Note
1	Plate A	Aluminum alloy	Anodized
2	Plate B	Aluminum alloy	Anodized
3	Slider body	Aluminum alloy	Anodized
4	External slider tube	Aluminum alloy	
5	Body wear ring	POM	
6	Piston	Aluminum alloy	
7	Shaft	Stainless steel	
8	Slider side yoke	Carbon steel	
9	Slider side magnet	Magnet material	
10	Piston side yoke	Carbon steel	
11	Piston side magnet	Magnet material	
12	Tube	Stainless steel	
13	Lub-retainer	Special resin	
14	Piston seal	NBR	
15	Wear ring	POM	

No.	Part name	Material	Note
16	O ring	NBR	
17	Guide shaft A	Carbon steel	
18	Guide shaft B	Carbon steel	
19	Bush	Copper	
20	Adjusting bolt	Carbon steel	
21	Cushion	PU	
22	Bolt	Carbon steel	
23	Hex socket screws	Carbon steel	
24	Switch rail	Aluminum alloy	for with magnet
25	Socket bolt	Carbon steel	for with magnet
26	Hex socket screws	Stainless steel	for with magnet
27	Magnet	Magnet material	for with magnet
28	Wear ring	POM	for with magnet
29	Washer	Aluminum alloy	Anodized
30	Snap ring	Spring steel	

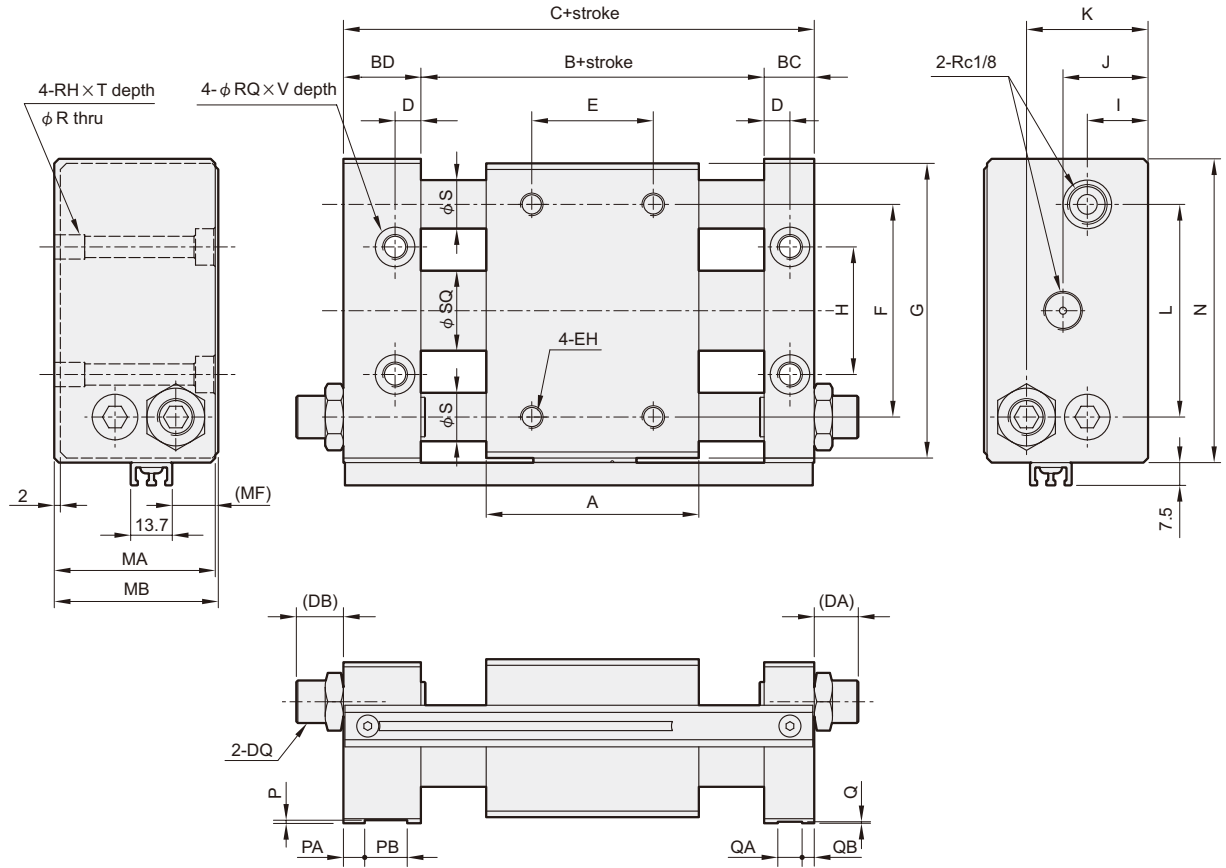

Code Tube I.D.	A	B	BC	BD	C	D	DA	DB	DQ	E	EH	F	G	H	I	J	K	L	MA	MB
20	70	73	16.5	25.5	115	8.5	16.5	17.5	M10 x 1.0	40	M6 x 1 x 10 depth	70	87	38	17	24	36	62	45	46
25	70	73	16.5	25.5	115	8.5	14.5	15.5	M14 x 1.5	40	M6 x 1 x 10 depth	70	97	42	20	28	40	70	53	54

Code Tube I.D.	MF	N	P	PA	PB	Q	QA	QB	R	RH	RQ	S	SQ	T	V	ZA	ZB
20	10	90	—	—	—	—	—	—	5.5	M6 x 1.0	9.5	16	21.6	9.5	5.5	29	20
25	14	100	1	7	14	0.5	8	4	7	M8 x 1.25	12	16	26.4	10	6.5	49	40

### With shock absorber

