

MEQYC-50L series

ROD ELECTRIC CYLINDER - BALL SCREW DRIVE (WITH MOTOR)

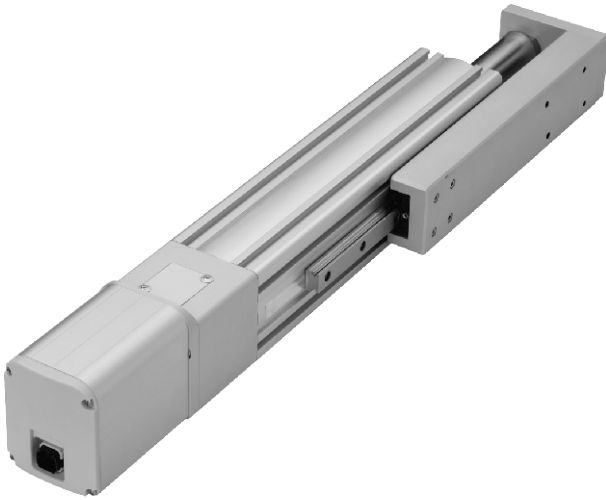

Mindman



Specification

Model	MEQYC-50L	
Repeatability (mm)	±0.01	
Ball screw lead (mm)	5	10
Maximum speed (mm/s) ^{※1}	250	500
Maximum payload	Horizontal(kg)	30
	Vertical (kg)	15
Rated thrust (N)	565	283
Stroke / pitch (mm) ^{※2}	50~300 / 50 Pitch	
Motor dimension (mm)	□42	
Ball screw spec (mm)	C7 φ 12	
Anti-rotating accuracy (θ) ^{※3}	±0.05°	

※1. The maximum speed shown here is when software speed setting is 100%.
When the stroke is over 200mm, the run-out of the ball screw will occur.

※2. We recommend to low down the working speed under this circumstances.

※3. Anti-rotating accuracy of plate

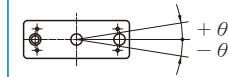

Order example of cylinder

MEQYC-50L — L05 — 100 — M — TC100 — 03 — A0001

Model	Spec.					Special order no.
Ball screw brand	Ball screw lead	Stroke	Motor position	Corresponding controller	Cable length	
L T-Standard MIT	05 5 mm 10 10 mm	50~300 mm 50 mm pitch	M Built-in BM On lower side BR On right side BL On left side	TC100 ※ Please refer to 4-126.	01 1m 03 3m 05 5m 10 10m ※ Standard: 3m	

Order example of controller

TC100 — 03

Controller	Cable length
TC100	Blank No cable 01 1m 03 3m 05 5m 10 10m ※ Standard: 3m

Speed-payload curve diagram

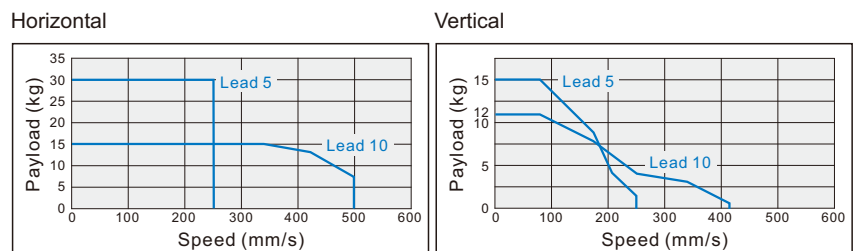

MEQYC-50L Dimensions

ROD ELECTRIC CYLINDER - BALL SCREW DRIVE (WITH MOTOR)



Mindman

M

Motor built-in

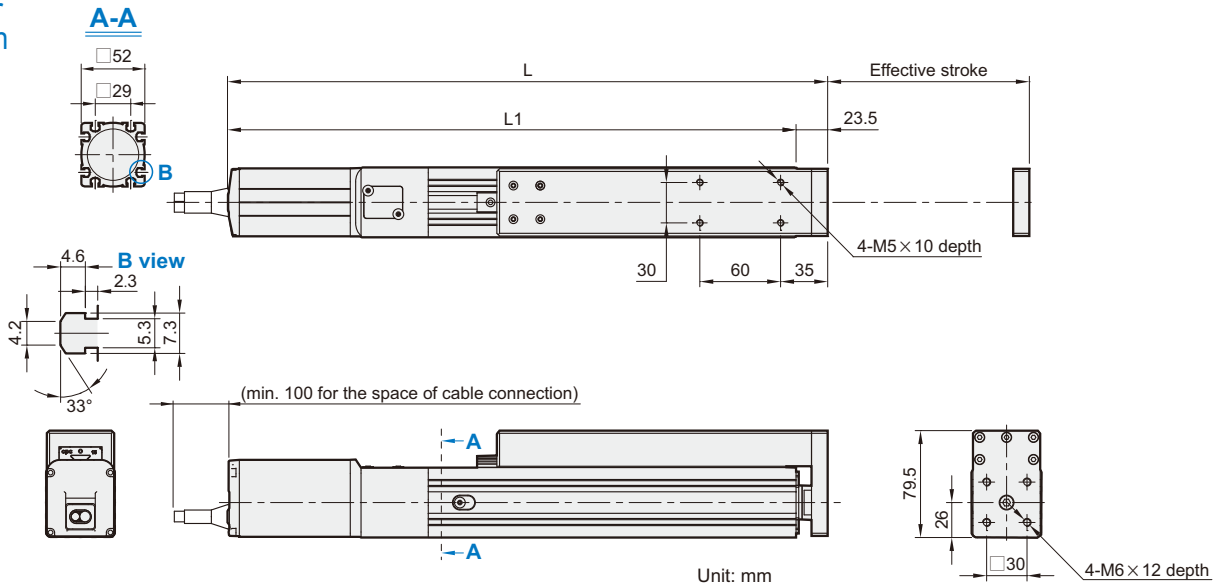

Unit: mm

Stroke	50	100	150	200	250	300
L	346.5	396.5	446.5	496.5	546.5	596.5
L1	323	373	423	473	523	573
KG	3.12	3.38	3.64	3.9	4.17	4.34

BM

Motor on lower side

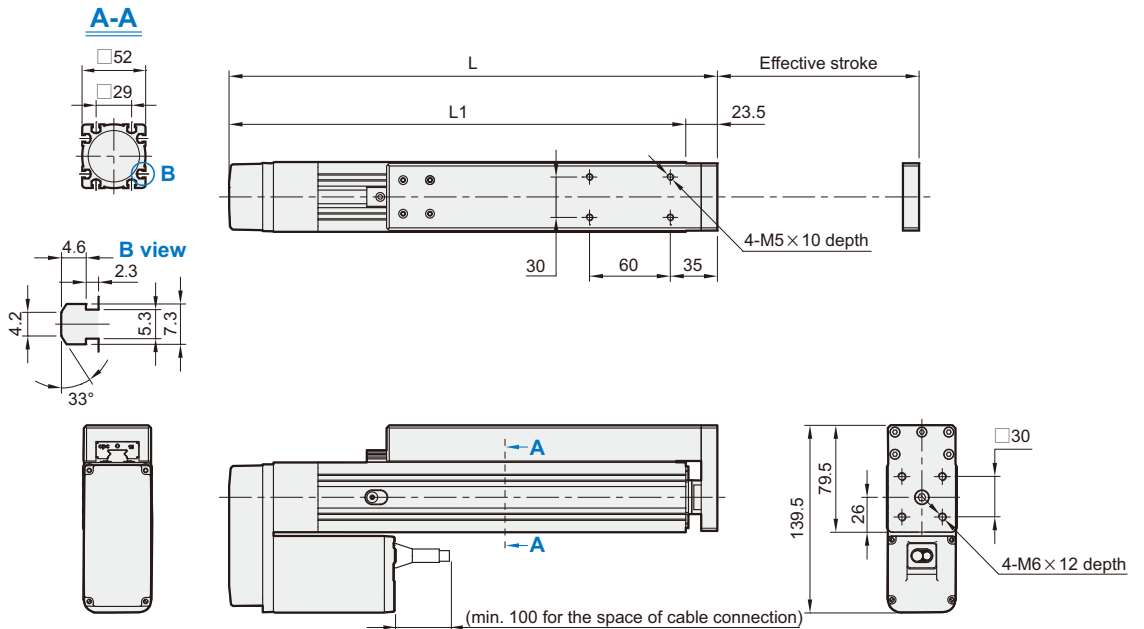

Unit: mm

Stroke	50	100	150	200	250	300
L	248.5	298.5	348.5	398.5	448.5	498.5
L1	225	275	325	375	425	475
KG	3.62	3.88	4.14	4.4	4.67	4.84

MEQYC-50L Dimensions

ROD ELECTRIC CYLINDER - BALL SCREW DRIVE (WITH MOTOR)



Mindman

BL

Motor on left side

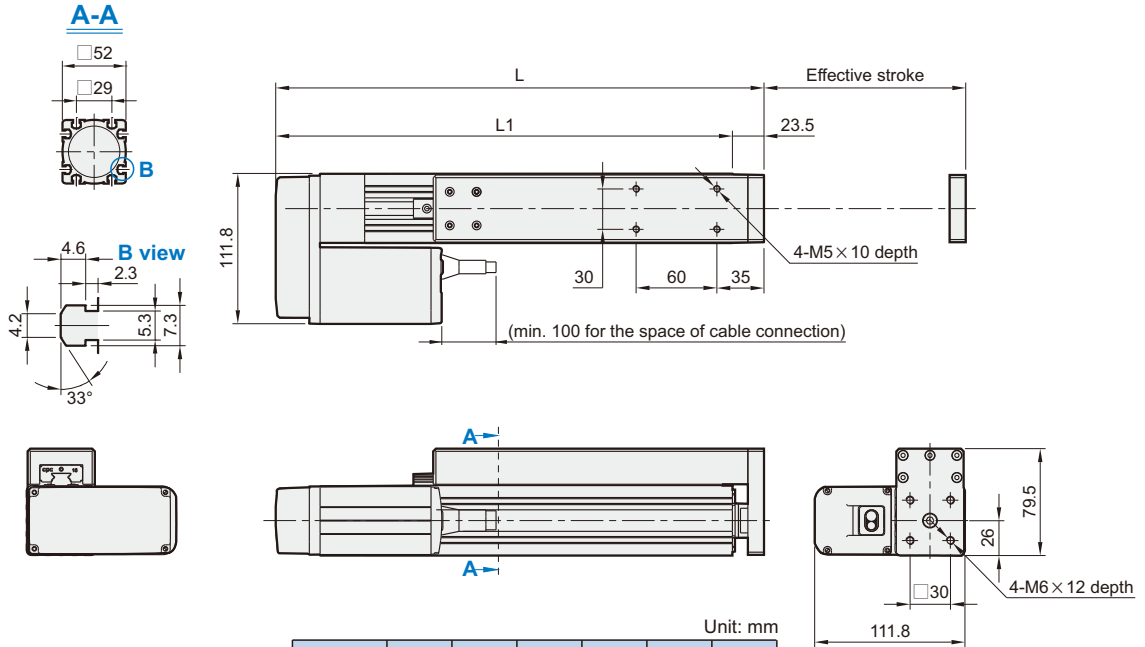

Unit: mm

Stroke	50	100	150	200	250	300
L	248.5	298.5	348.5	398.5	448.5	498.5
L1	225	275	325	375	425	475
KG	3.62	3.88	4.14	4.4	4.67	4.84

BR

Motor on right side

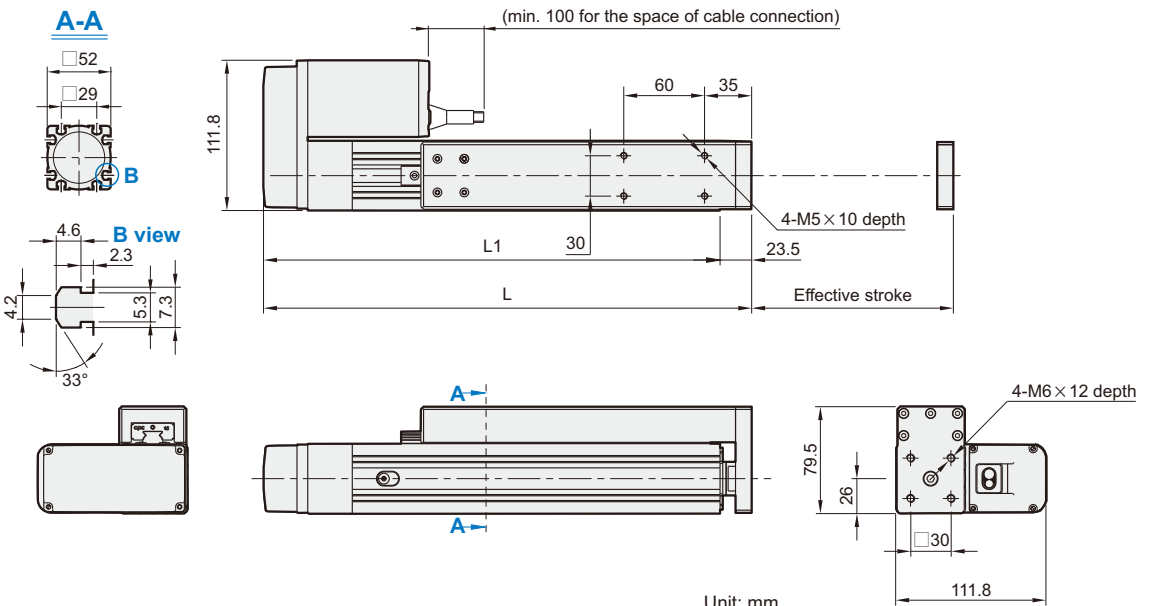

Unit: mm

Stroke	50	100	150	200	250	300
L	248.5	298.5	348.5	398.5	448.5	498.5
L1	225	275	325	375	425	475
KG	3.62	3.88	4.14	4.4	4.67	4.84