

- Used extensively for providing smooth consistent feed speed on machine tools.
- Construction incorporates double seal enabling unit to be used in dirty and dusty environments.
- Fully adjustable speeds can be quickly and simply selected.
- Compact size, ideal for use on robots, drills, conveyors, cut off machines and woodworking equipment.
- Can be used in conjunction with Pneumatic air cylinder in order to provide consistent movement.

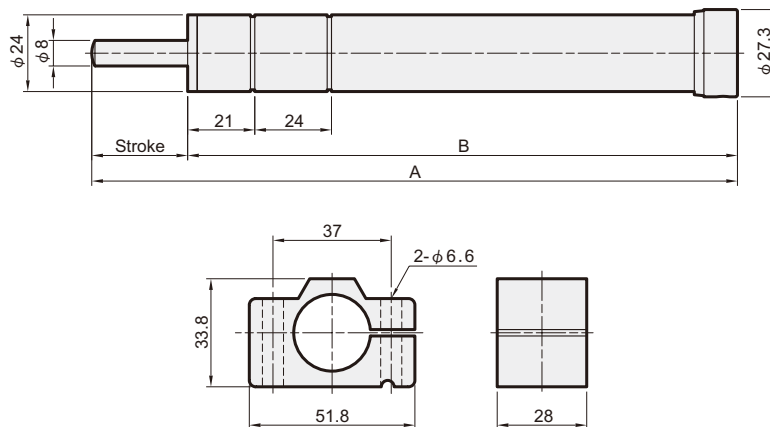

Specification

Order no.	A	B	Max. stroke (mm)	Operating temperature (°C)	Max. load	Weight (g)
MHR 30	202	172	30 mm	0-60°C	15~350kg	495 g
MHR 60	282.5	222.5	60 mm	0-60°C	15~350kg	615 g
MHR 80	350	270	80 mm	0-60°C	15~350kg	690 g
MHR 100	396	296	100 mm	0-60°C	15~350kg	765 g



Application example

