

MVSY-156 series

SOLENOID VALVE

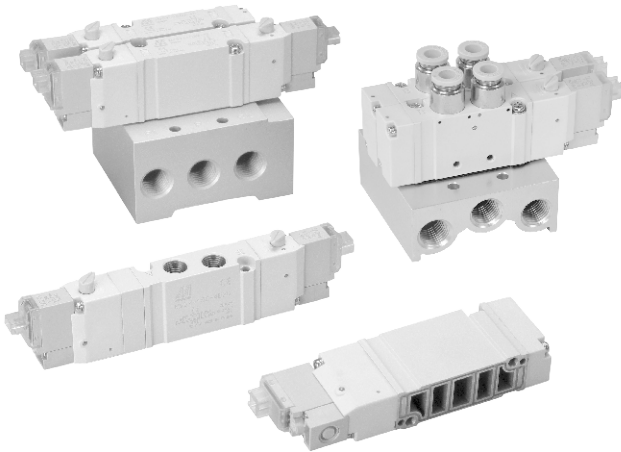

Mindman



Specification

Model	4E1	4E2	4E2C.P.R
Bore No.	6A		
Port size	Rc1/8		
No. of port	5		
No. of position	2	3	
Medium	Air		
Operating pressure range	0.15~0.7 MPa		0.2~0.7 MPa
Proof pressure	1 MPa		
Effective orifice	Body ported	11 mm ²	9.5 / 14.6 / 9.5 mm ²
	Manifold	10 mm ²	7.5 / 13 / 8 mm ²
Response time	19 ms		20 ms
Ambient temperature	+5~+50°C		
Voltage	AC110V, AC220V (50/60)Hz, DC6/12/24V		
Power consumption	AC=1.6 / 2.5VA, DC6/12V=1.2W, DC24V=0.55W		
Available voltage range	± 10%		
Insulation class	B class		
Weight	68g	87g	96g

※ LED indicator as standard.

Order example of valve

MVSY – 156M – 4E2C – AC110 – LJ1 – G

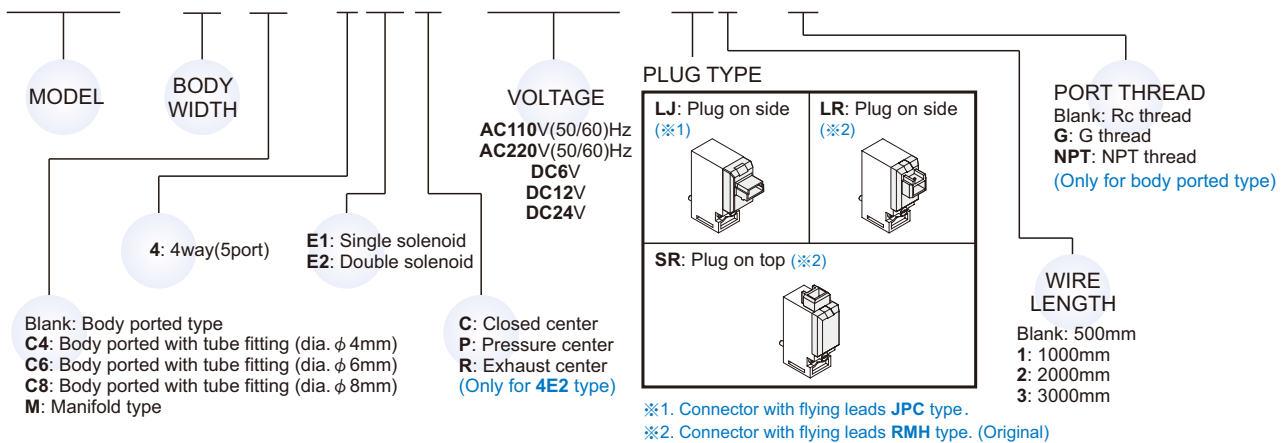

Order example of manifold

MVSY – 156M – 5M3 – G

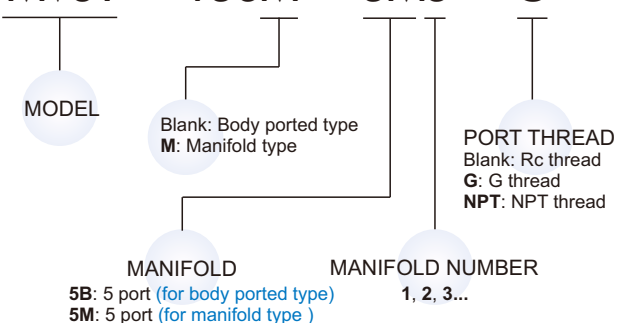

Order example of wire

MVDY – 100 – WA2J2

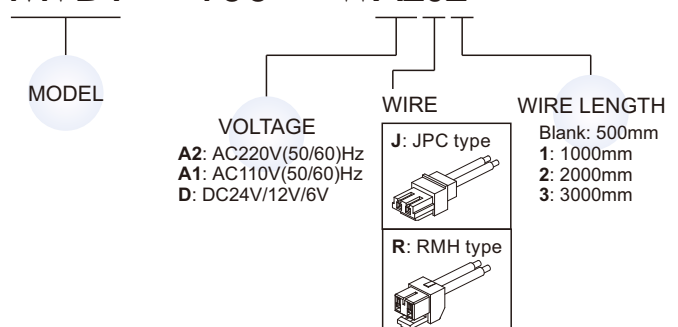

MVSY-156 Dimensions

SOLENOID VALVE



MVSY-156-4E1

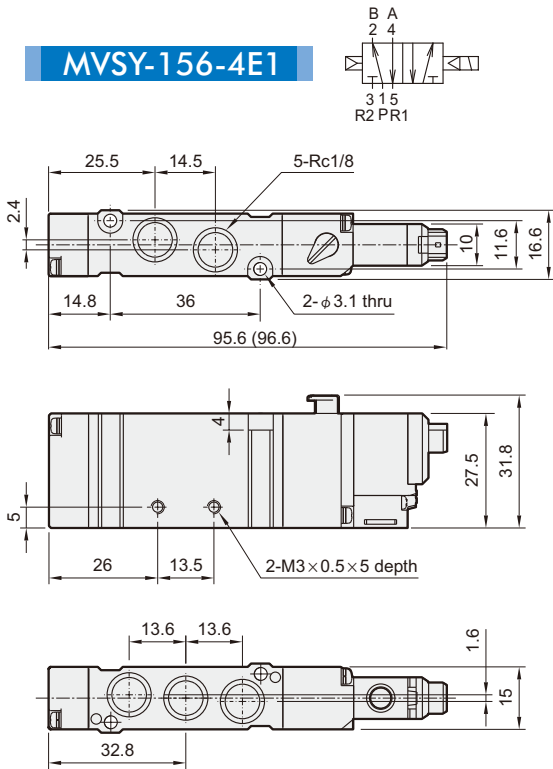

MVSY-156-4E2

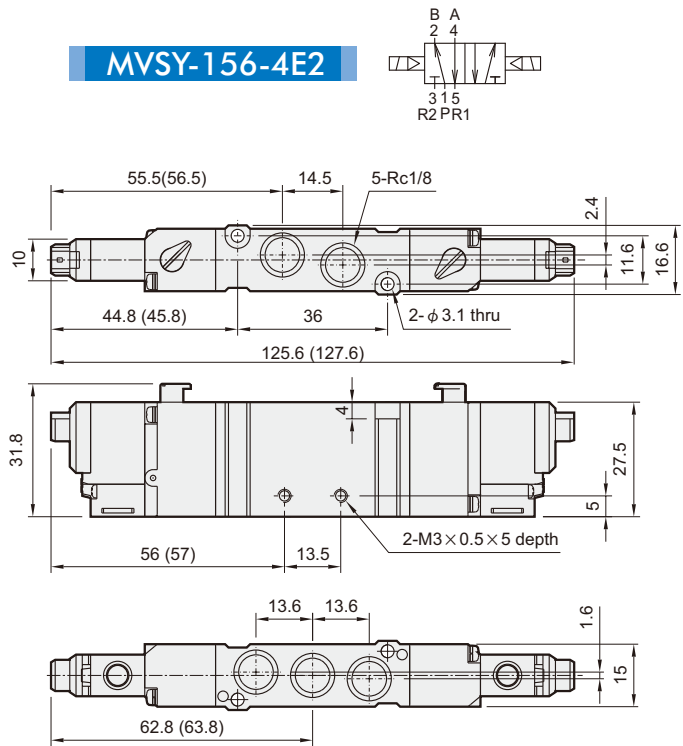

MVSY-156-4E2C.PR

MVSY-156-4E2C

MVSY-156-4E2P

MVSY-156-4E2R

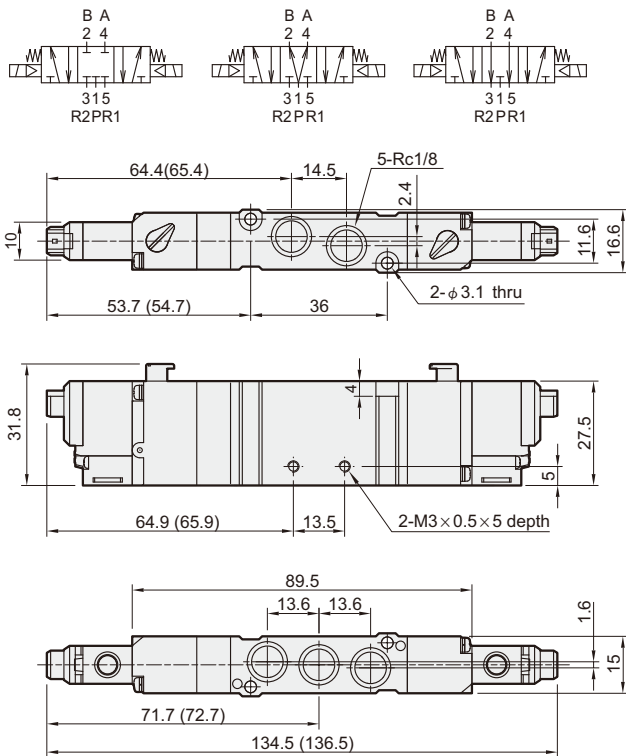

Flow features

MVSY-156-4E1/4E2

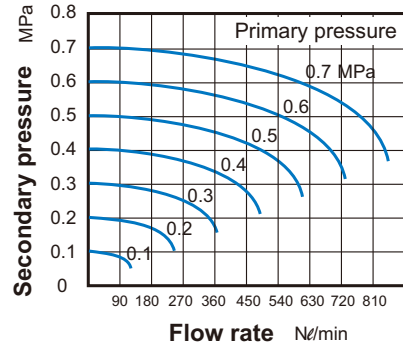

MVSY-156M-4E1/4E2

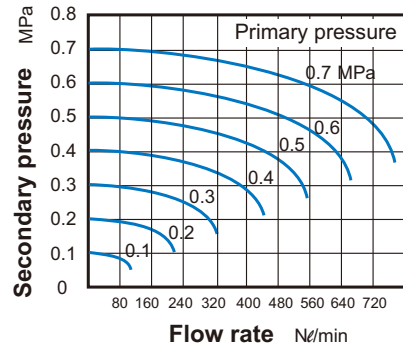

(): Dimension for LJ plug type.

MVSY-156 Dimensions

SOLENOID VALVE



MVSY-156C*-4E1

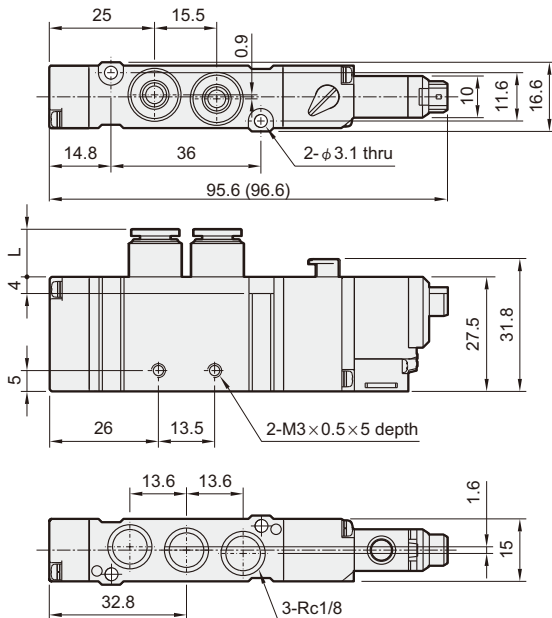
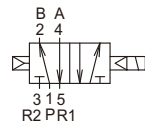

MVSY-156C*-4E2

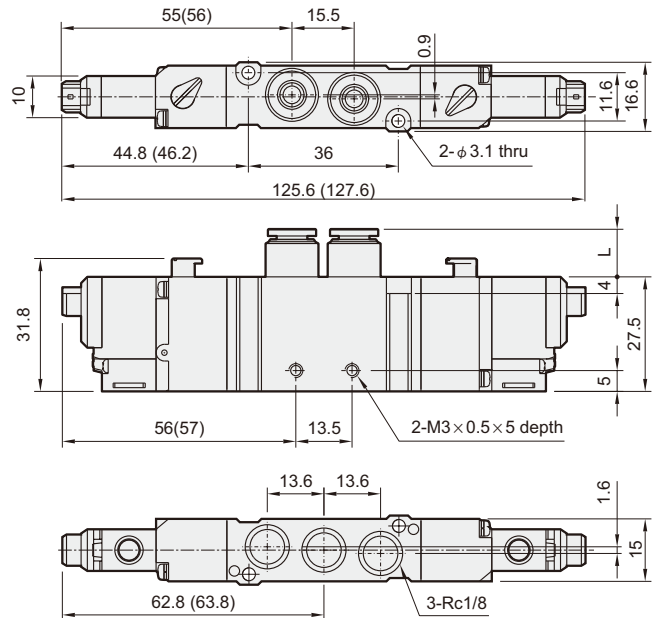
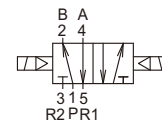

MVSY-156C*-4E2C.PR

MVSY-156-4E2C

MVSY-156-4E2P

MVSY-156-4E2R

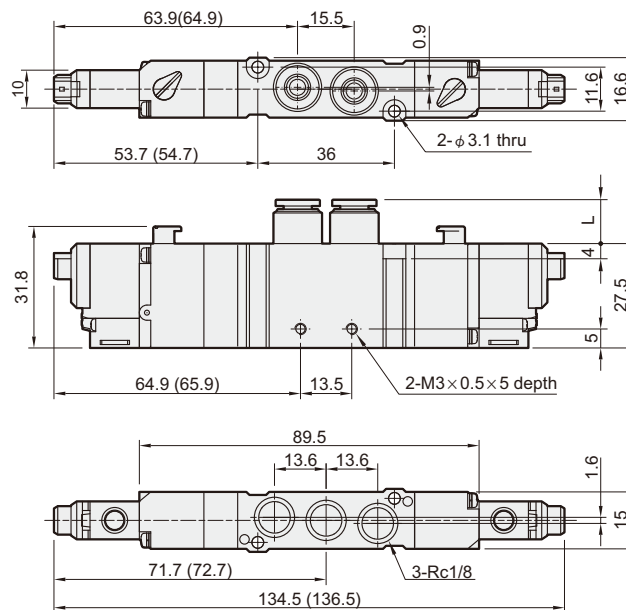
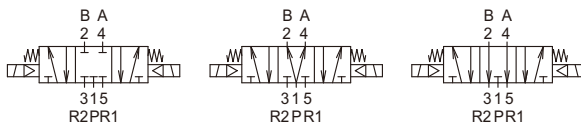

Code Port size	L
C4	13
C6	14
C8	18.5

(): Dimension for LJ plug type.

MVSY-156 Manifold

SOLENOID VALVE



MVSY-156-5B*

5 port (for body ported type)

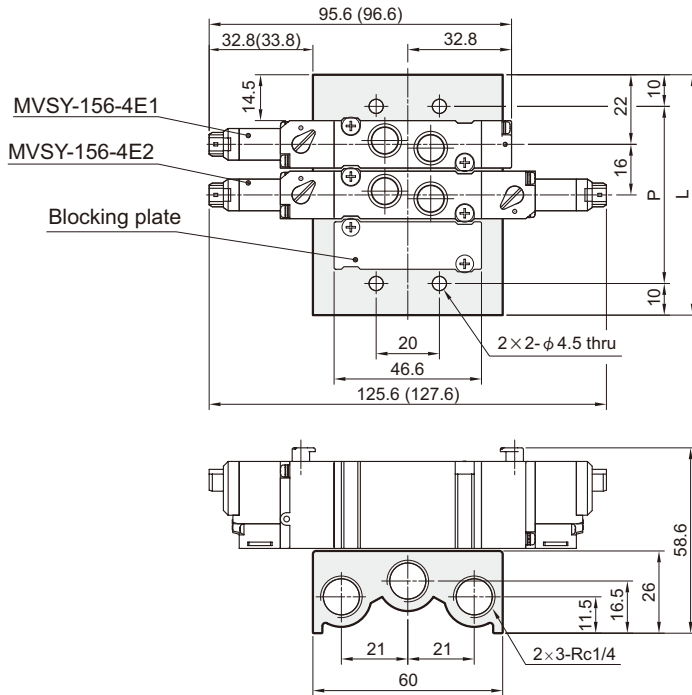

No. of stations	P	L
2	40	60
3	56	76
4	72	92
5	88	108
6	104	124
7	120	140
8	136	156
9	152	172
10	168	188

MVSY-156M-5M*

5 port (for manifold type)

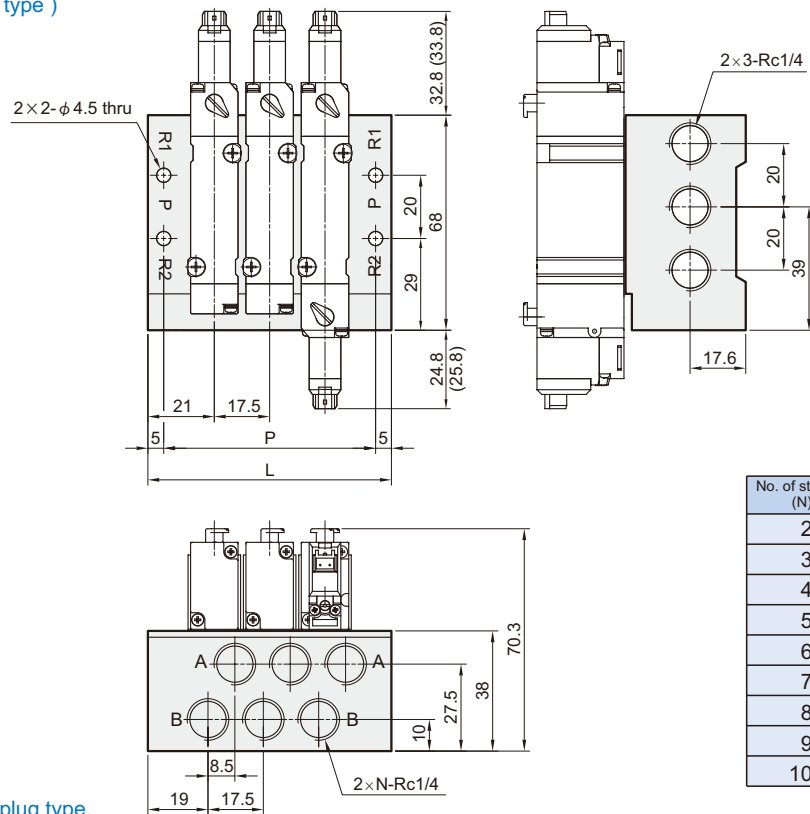

No. of stations (N)	P	L
2	49.5	59.5
3	67	77
4	84.5	94.5
5	102	112
6	119.5	129.5
7	137	147
8	154.5	164.5
9	172	182
10	189.5	199.5

(): Dimension for LJ plug type.

MVSY-156 Mounting bracket / Spacer assembly

SOLENOID VALVE



Order example of bracket

MVSY – 156 – 1A

MODEL

MOUNTING BRACKET
1A
2A

Order example of spacer assembly

MVSY – 156M – 5BP

MODEL

Blank: Body ported type
M: Manifold type

5B: 5 port (for body ported type)
5M: 5 port (for manifold type)

SPACER
ASSEMBLY

P: Individual SUP spacer assembly
R: Individual EXH spacer assembly
PR: Individual SUP spacer assembly+
Individual EXH spacer assembly

MVSY-156-1A

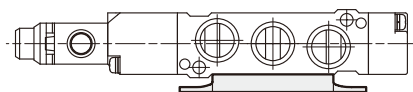
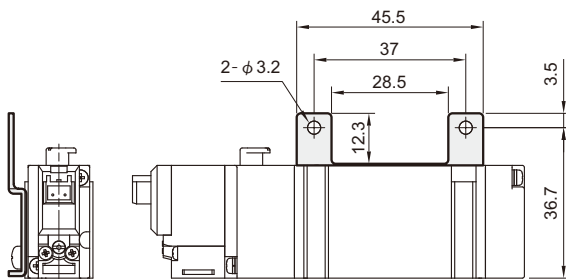
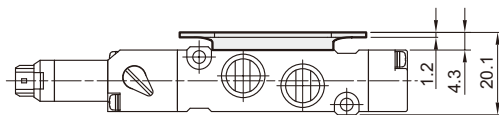
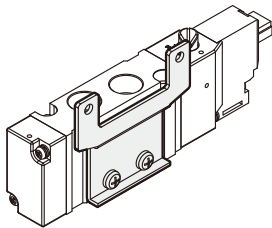

MVSY-156-2A

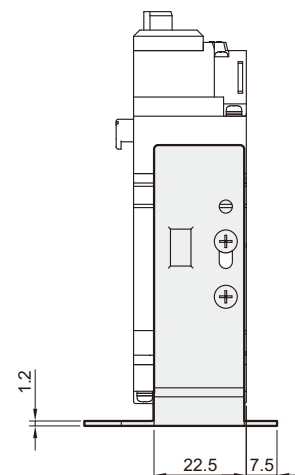
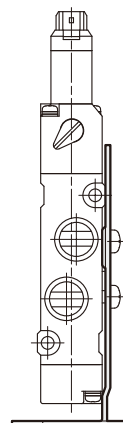
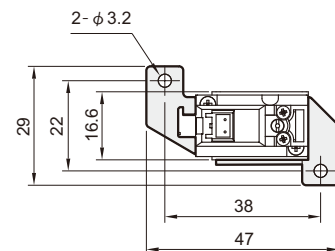
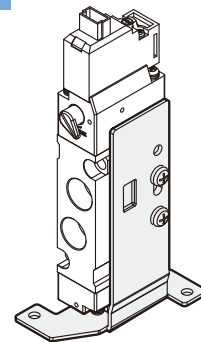

MVSY-156 Spacer assembly

SOLENOID VALVE



mindman

for body ported type

MVSY-156-5BP

Individual SUP spacer assembly

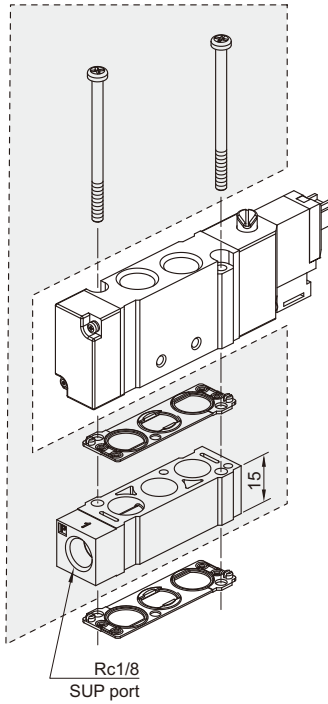

MVSY-156-5BR

Individual EXH spacer assembly

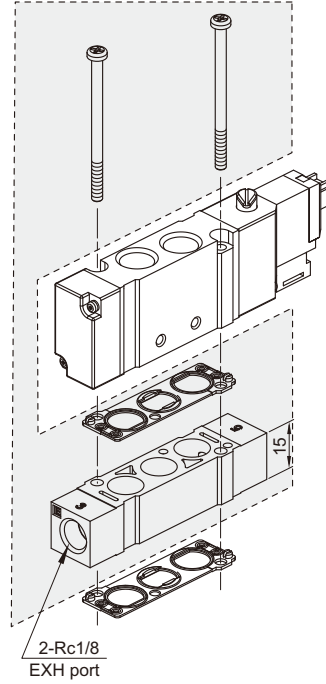

MVSY-156-5BPR

Individual SUP spacer assembly + Individual EXH spacer assembly

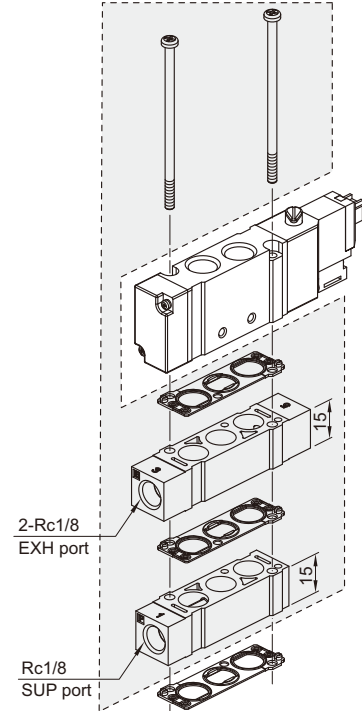

for manifold type

MVSY-156M-5MP

Individual SUP spacer assembly

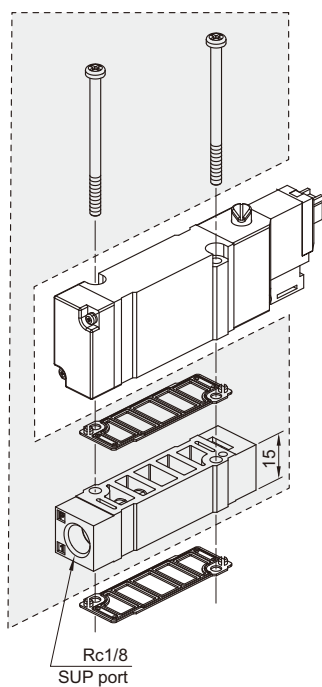

MVSY-156M-5MR

Individual EXH spacer assembly

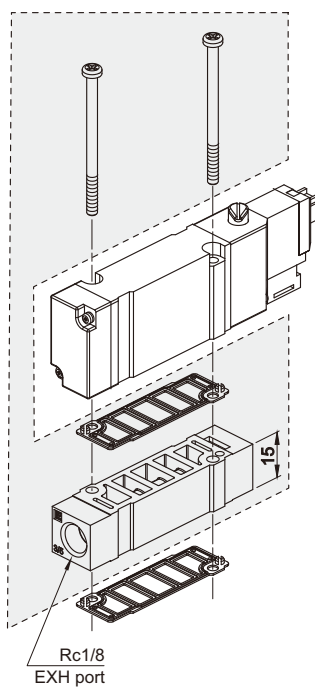

MVSY-156M-5MPR

Individual SUP spacer assembly + Individual EXH spacer assembly

